



Equatorial Ionosphere - A tutorial

*Babatunde Rabi
Centre for Atmospheric Research
National Space Research & Development Agency
NASRDA
Anyigba, Nigeria*

Email: tunderabiu@cnasrda.com; tunderabiu2@gmail.com



Outline of presentation

- The ionosphere
- Relevance of the Ionosphere
- Equatorial ionosphere
- **Some results/observations**

The Ionosphere

- Upper part of the earth's atmosphere where electrons exist in sufficient proportion as to affect the propagation of radio waves
- 50 km – 1000 km
- Encompasses satellite altitudes

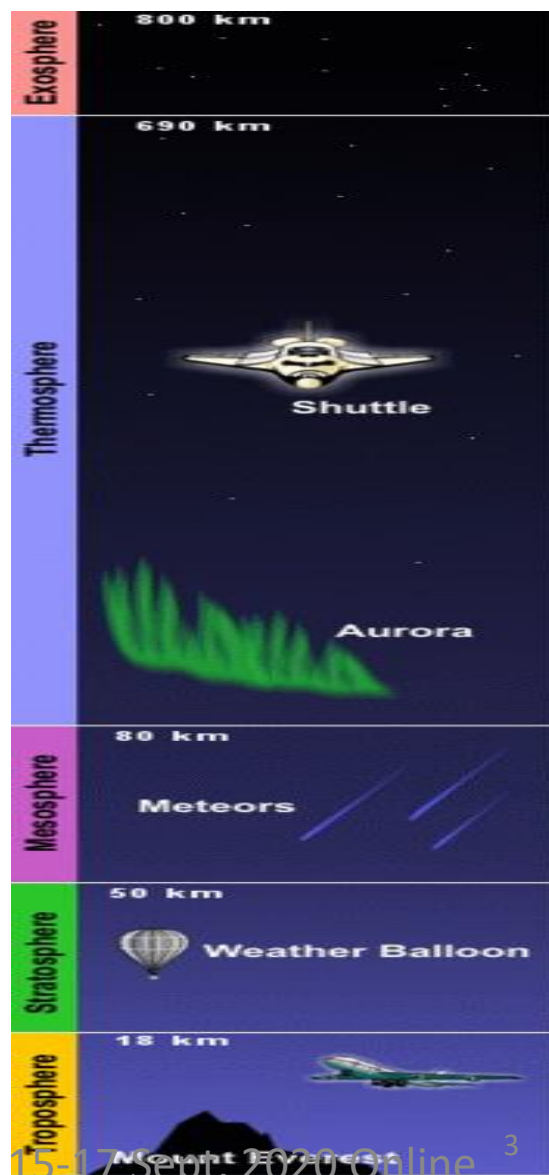
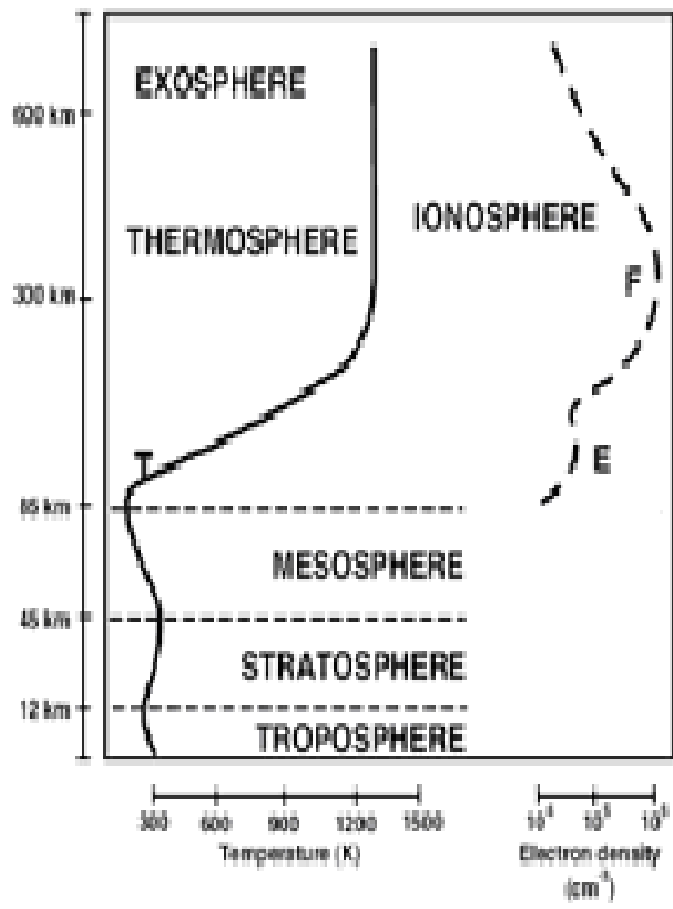

Ionospheric layers

Stratified layers

Varying concentration

- D
- E
- F1
- F2 (F1 & F2 combine at night to form single F layer)

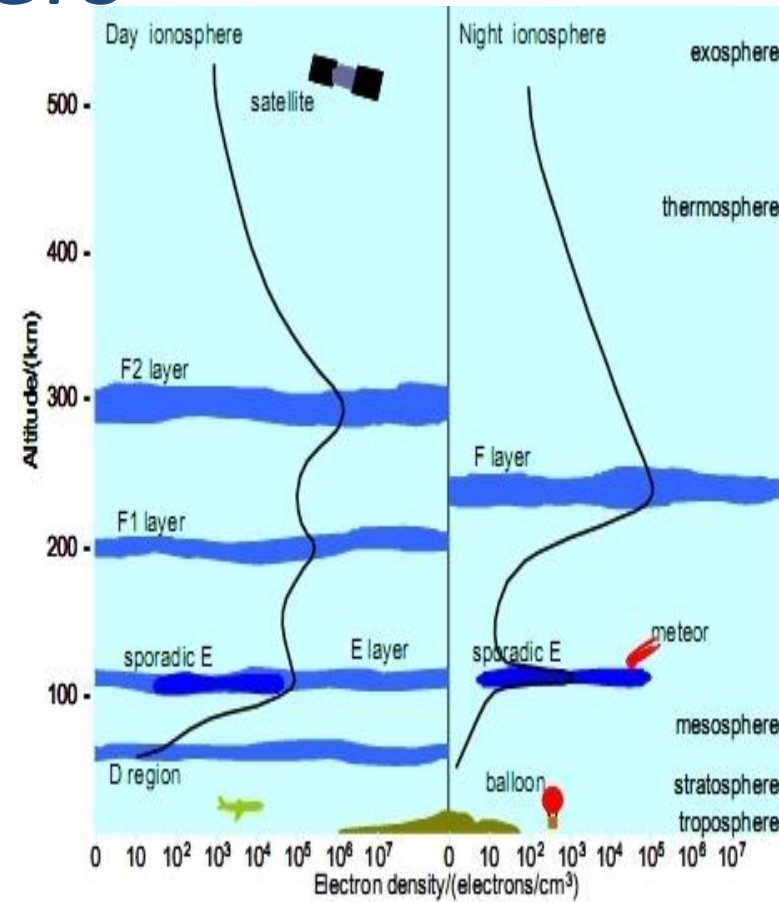

Characterizing the ionosphere is of utmost interest due to the numerous complexities associated with the region [Rabiou, et al., 2007]



Relevance of the Ionosphere

- Radio propagation....
- Long-distant communication HF., VHF...
- Transmission: reflective and refractive property
- Attenuation/absorption
- Impact on Earth-Satellite Communication
- Scintillation
- etc



Equatorial Ionosphere

Magnetic Equator

- **Magnetic (dip) equator is defined as the locus of zero dip along the surface of the earth (Cohen, 1967)**
- **Its latitude varies along the geographical longitudes**

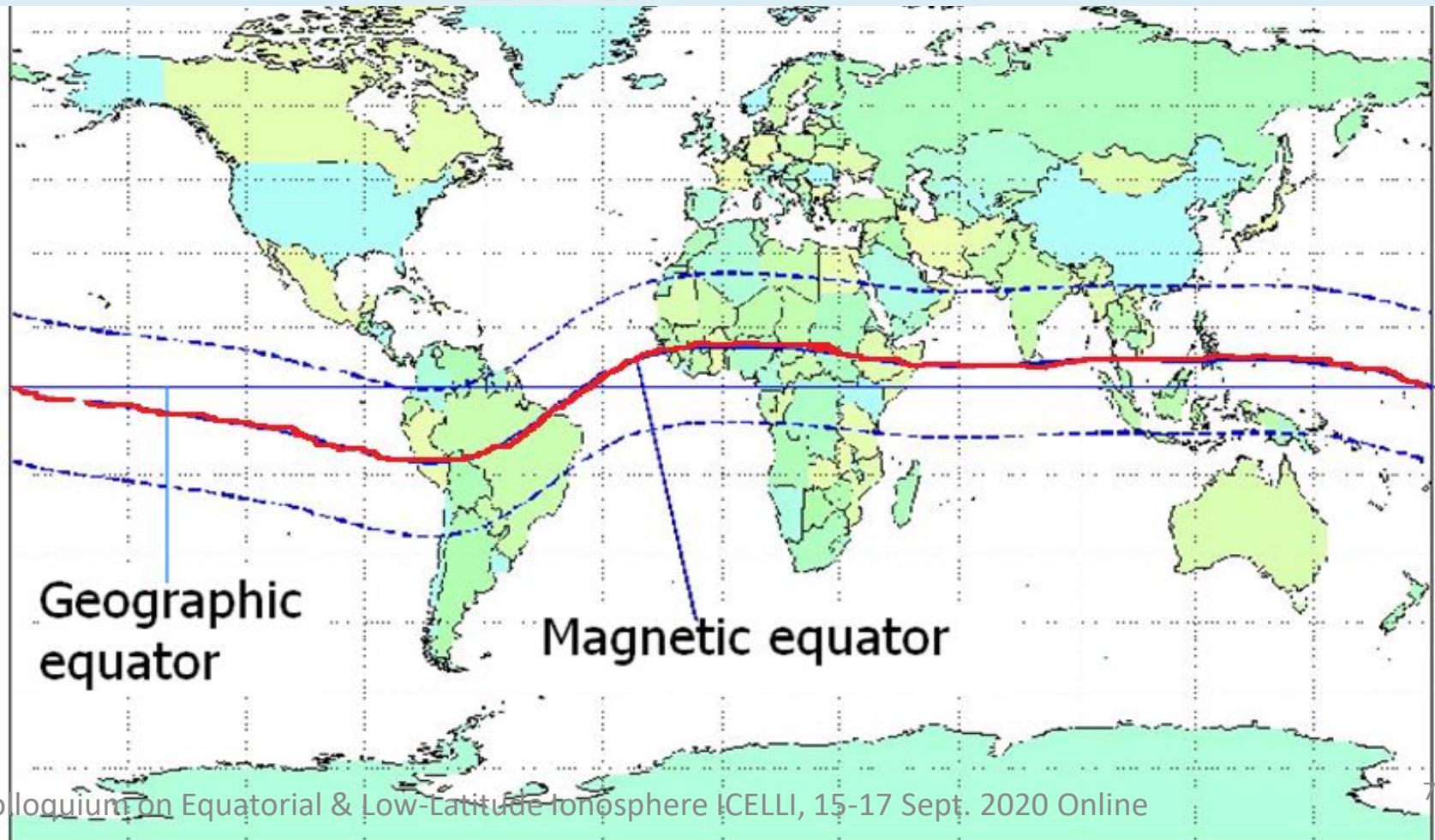



Magnetic Equator

- In the neighbourhood of magnetic equator, there is an unusual orientation of the magnetic field with relation to the Earth
- Charged particles move more readily along magnetic field lines
- Migration of charged particles along geomagnetic field lines is associated with a two-humped latitudinal distribution of electron density, with minimum at the magnetic equator

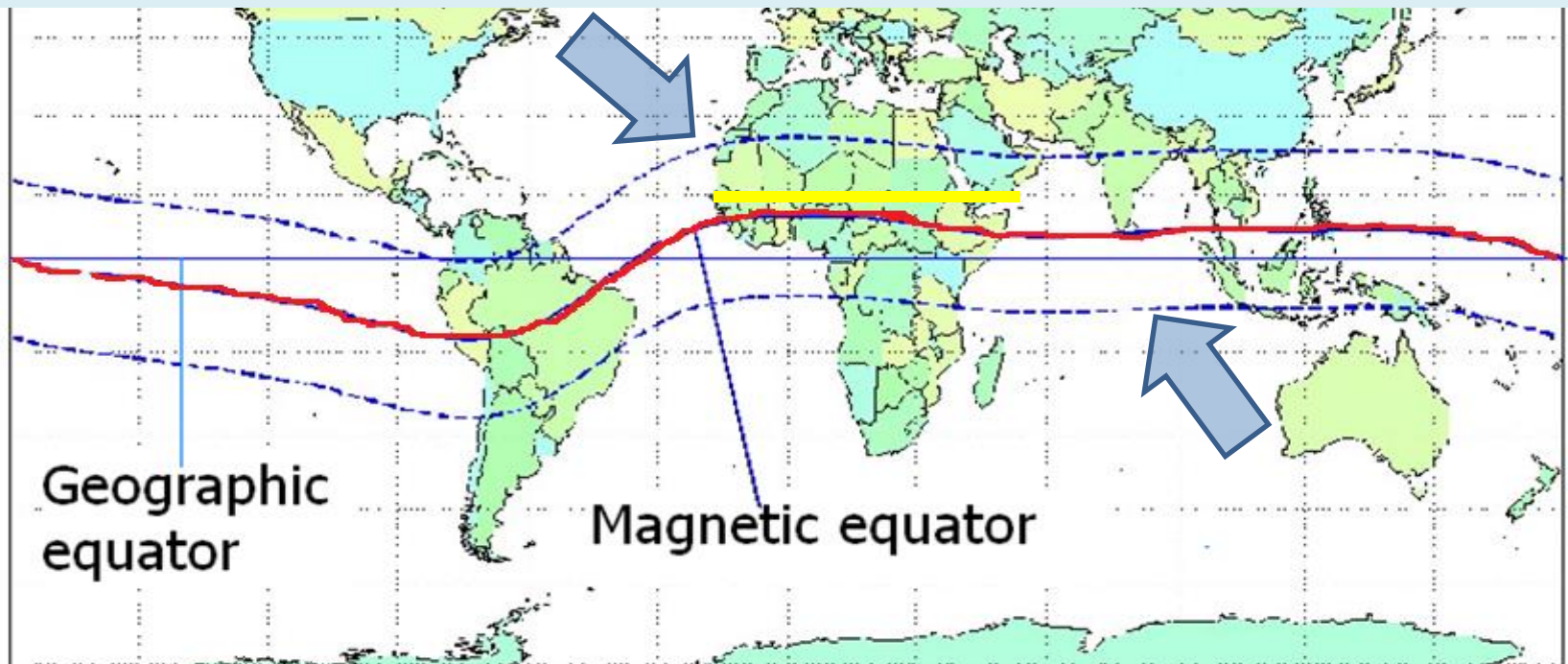

Africa has the broadest inland range of magnetic equator over it

3 major regions of the global ionosphere

- high-latitude $\pm 60^\circ - 90^\circ$
- mid- latitude $\pm 20^\circ - 60^\circ$
- equatorial $\pm 0 - 20^\circ$

Magnetic latitudes

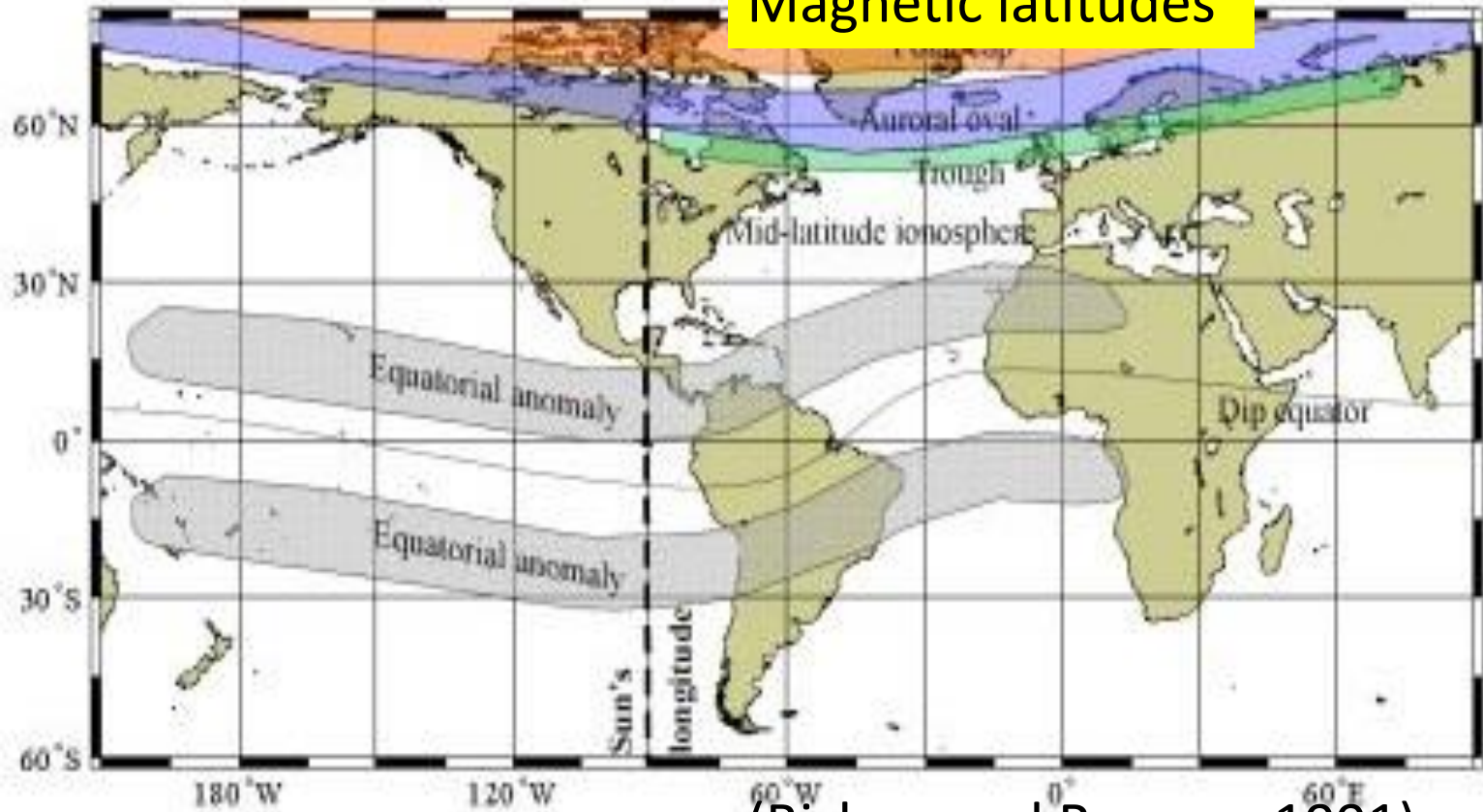

(Bishop and Rossow. 1991).



Equatorial Region 1

- characterized with the highest values of the peak-electron density with the most pronounced amplitude and phase scintillation effects
- The combined effect of the high radiation level from the sun, & the electric and the magnetic fields of the earth results in the electrons rising and moving along the horizontal lines of the magnetic field, forces ionization up into the F layer, concentrating at $\pm 20^\circ$ from the magnetic equator this phenomenon is called the fountain effect.
- The electrons move as far as the geomagnetic latitudes of 10 to 20° causing the high concentration of electrons there which are often termed equatorial anomalies (Komjathy, 1997).



Equatorial Region 2

- The worldwide solar-driven wind results in the so-called Sq (daily solar quiet) current system in the E region of the Earth's ionosphere (100–130 km altitude)
- Resulting from this current is an electrostatic field directed E-W (dawn-dusk) in the equatorial day side of the ionosphere
- At the magnetic dip equator, where the geomagnetic field is horizontal, this electric field results in an enhanced eastward current flow within $\pm 3^\circ$ of the magnetic equator, known as the equatorial electrojet

(Onwumechili, 1992a, 1992b, 1997 Komjathy, 1997, & Rabiou et al, 2013)



Equatorial Ionosphere

- E layer – Equatorial electrojet
- F layer – Equatorial anomaly, Spread F.



Equatorial Ionospheric Anomaly EIA

- The F2 layer in the vicinity of the magnetic dip equator is characterized by a depression in the ionization density or “trough” at the equator and two humps, one on each side of the equator (at about $\pm 17^\circ$ *magnetic latitude*) during the day that lasts for several hours after sunset.
- This interesting phenomenon is called the “equatorial anomaly” or “Appleton anomaly” (Appleton, 1946). The cause of the anomaly is often attributed to the so-called “fountain effect”
- it is the eastward electric field at the equator that gives rise to an upward $E \times B$ drift during the daytime.
- After the plasma is lifted to greater heights it is able to diffuse downward along magnetic field lines under the influence of gravity and pressure gradient forces.
- The net result is the formation of a plasma “fountain” which produces an enhanced plasma concentration (crest) at higher latitudes and a reduced plasma concentration (trough) at the equator

Equatorial Plasma Fountain

- The daytime dynamo generated eastward electric field combined with the northward geomagnetic field lifts the equatorial ionosphere to 700 km to over one thousand kilometers.
- After losing momentum, the electrons diffuse along the field lines to either side of the equator to form two crests

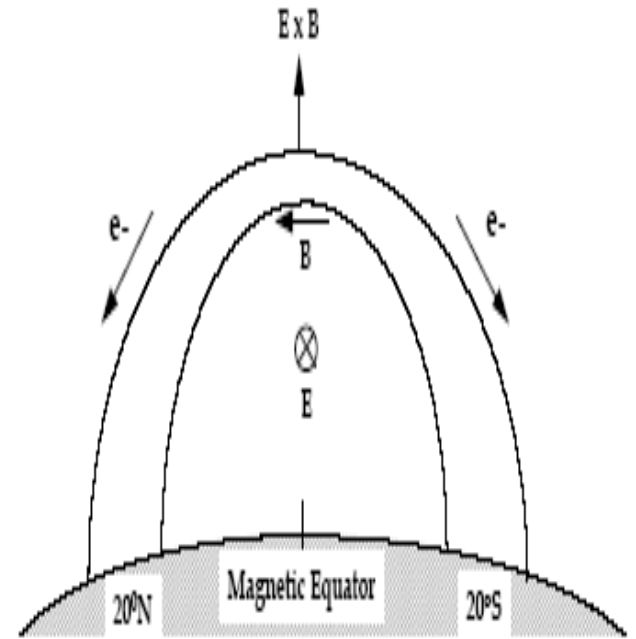

[Yeh et al 2001]

Equatorial Anomaly Crest

- In response to the diurnal variations of the dynamo electric field [Fejer, 1981], the anomaly crest begins to form around 09:00 LT on a normal day
- As time progresses, the anomaly crest intensifies and moves with a speed of about 1° per hour to a higher latitude

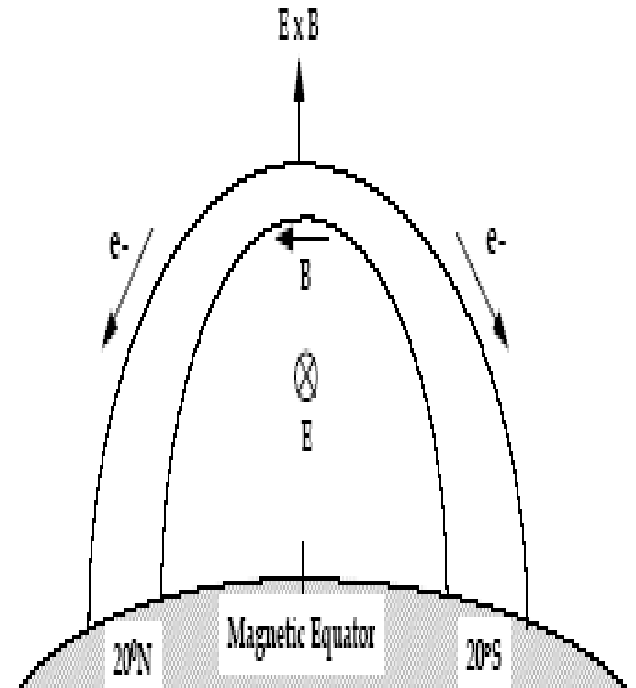

[Yeh et al 2001]

Equatorial Anomaly Crest

- This speed is maintained till shortly before noon when the poleward motion is slowed and reversed at around 14:00 LT
- During this time, the anomaly crest is most intense, showing the characteristic tilt, an approximate alignment of its core along the geomagnetic field lines and the asymmetric behavior
- Thereafter, the crest weakens and recedes slowly equatorward.
- On many days the crest is observed to linger into the night with a smaller spread in latitude

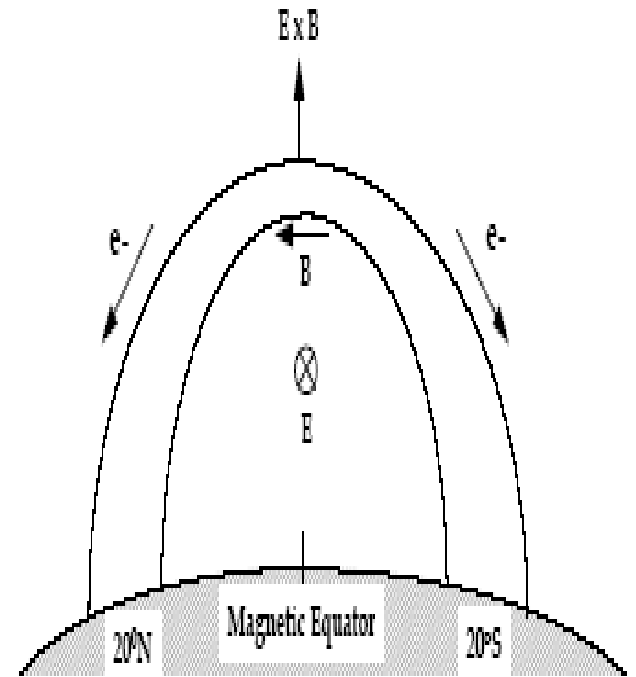

[Yeh et al 2001]

Equatorial Electrodynamics and the density structure

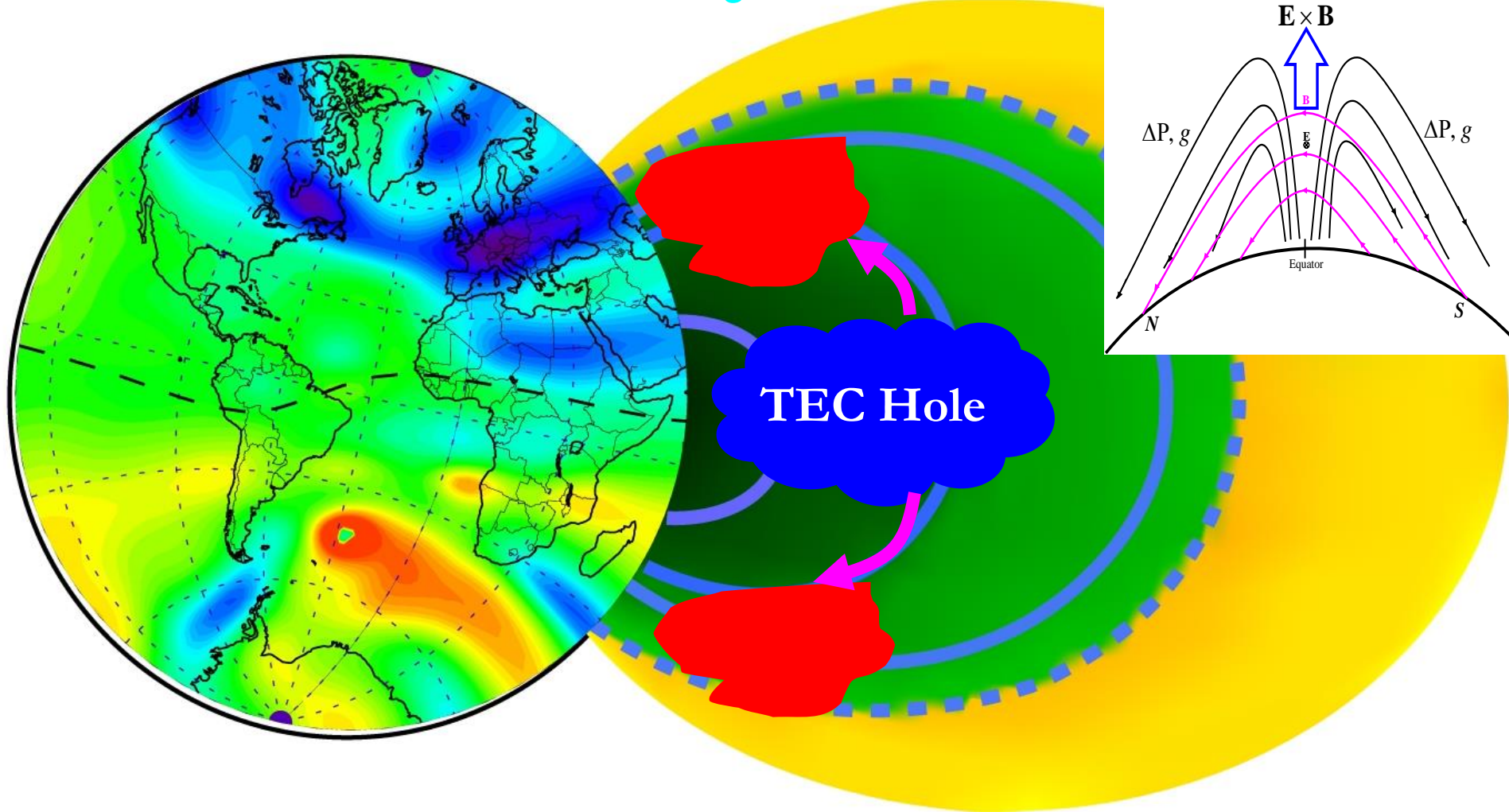

Courtesy: Endawoke Yizengaw , 2011. Equatorial Electrodynamics, vertical



Scintillations in Equatorial Region

- ✓ Ionospheric scintillations are rapid and temporal fluctuations in the amplitude and phase of transionospheric radio signals resulting from electron density irregularities in the ionosphere
- ✓ EIA -responsible for the formation of the plasma density irregularities that give rise to scintillations.



Equatorial Spread F ESF

- ✓ Irregularities in the equatorial F-region have been studied for decades
- ✓ Abundant ionospheric density irregularities in equatorial ionosphere
- ✓ These ionospheric irregularities are well known as equatorial spread-F (ESF) according to a nomenclature introduced after the appearance of **spread echoes on ionograms**.
- ✓ The term 'spread-F irregularities' is synonymous with electron density fluctuations or structures on scales ranging from a few tens of centimeters to several hundred kilometers.

Equatorial "Arcs"

Image of equatorial "arcs" and ionospheric irregularities over Africa, a spectacular example of space weather in the region. The image was obtained by the GUVI instrument on the TIMED satellite using the emissions at 135.6 nm from the recombination of O^+ ions with electrons. The increased airglow emission maps the equatorial ionization anomaly or "arcs," and the depletions within each arc that arise from the Rayleigh-Taylor instability.

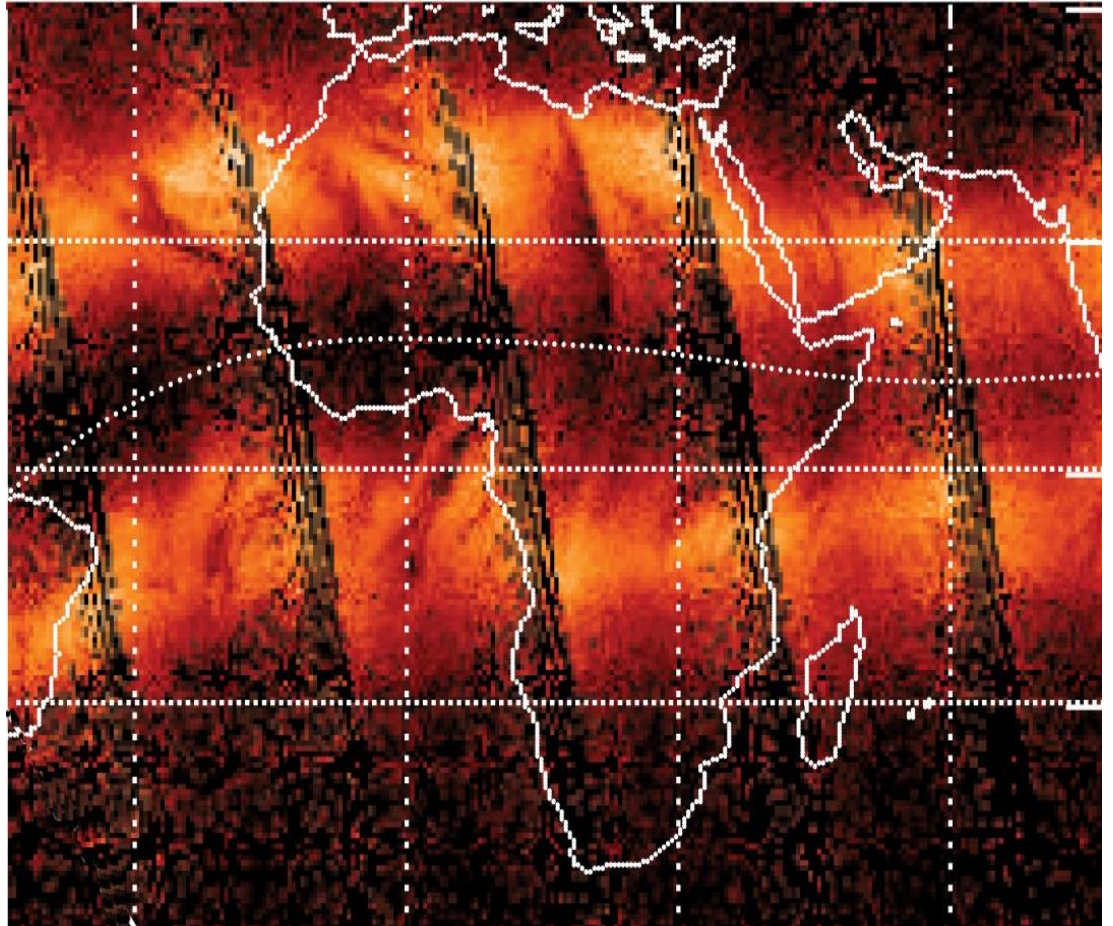

The observations from GUVI cover about 2000 km in each swath - the swath boundaries can be seen as the "dashed" regions that run from the left hand corner to the right hand corner. The brighter regions depicting the equatorial arcs follow the magnetic equator (indicated as a sinusoidal dotted line offset from the geographic equator).



Sq & EEJ

- solar quiet daily Sq currents is a worldwide ionospheric currents responsible for Sq variation in the Earth's magnetic field.
- Sq center is located at about 118 km and has a focus in each of the hemispheres (Onwumechili, 1997).
- In a narrow region around the dip equator, the H component of Sq field becomes very large and positive
- This sudden enhancement, first observed at Huancayo in 1922, has been attributed to a narrow intense ionospheric current which flow eastwards within the narrow strip flanking the dip equator (Egedal, 1947, and others)

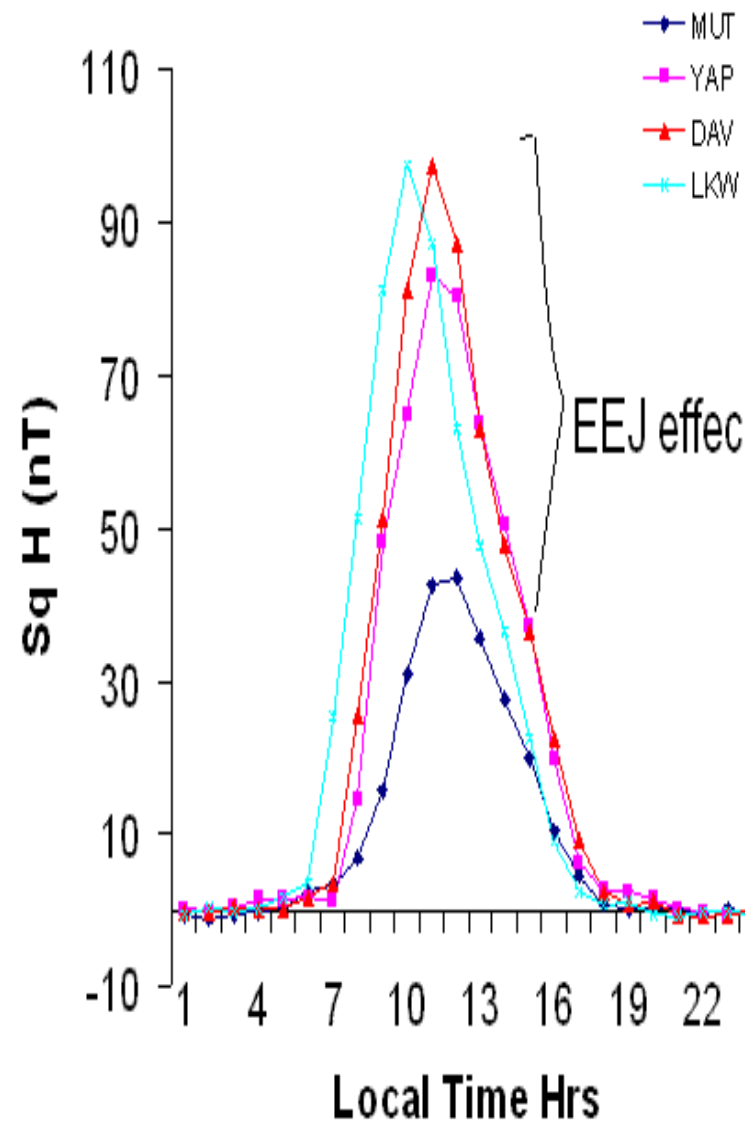

The enhancement of Sq at YAP, DAV and LAW on 8th April 2008 due to electrojet effect (After Rabiou et al, 2009a)

Sq & EEJ

- This unique equatorial ionospheric current was later, in May 1951, named by Sydney Chapman 'the Equatorial electrojet' in his presidential address to the Physical Society of London.
- On occasion, at quiet periods during certain hours of the day, particularly in the morning and evening hours, the EEJ reverses direction and flows westwards giving rise to the so-called 'counter electrojet (CEJ)' phenomenon (Gouin, 1962; Gouin and Mayaud, 1967).

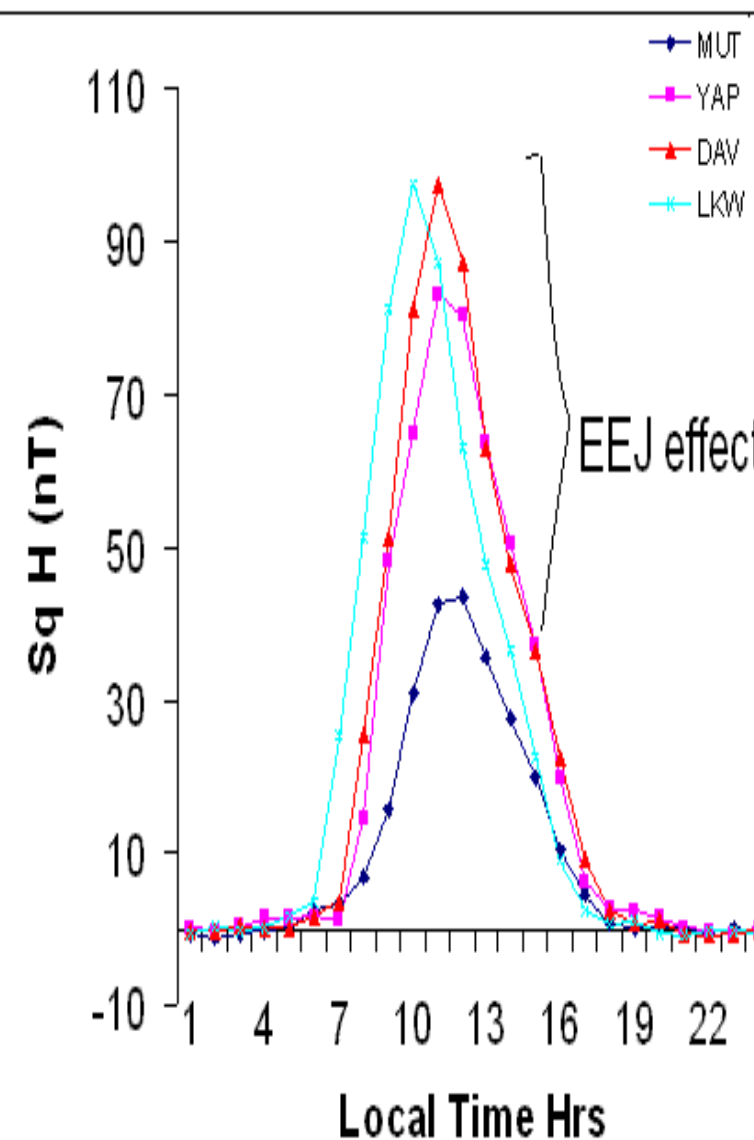

The enhancement of Sq at YAP, DAV and LKW on 8th April 2008 due to electrojet effect (After Rabiou et al, 2009a)



Equatorial Electrojet

- The E (dynamo) region of the equatorial ionosphere consists of 2 layers of currents responsible for the quiet solar daily variations in Earth's magnetic field:
- Worldwide solar quiet daily variation, WSq (altitude 118 ± 7 km), responsible for the global quiet daily variation observed in the earth's magnetic field.
- Equatorial electrojet, EEJ - an intense current flowing eastward in the low latitude ionosphere within the narrow region flanking the dip equator (altitude 106 ± 2 km) (Chapman, 1951, Onwumechili, 1992)
- Enhanced (Cowling) conductivity associated with the special equatorial magnetic field configuration results in the strong daytime EEJ currents



Manifestations of EEJ

- Spatial structures of its intense current density
- configurations & regular temporal variations of its current system
- magnetic fields of its current system
- the ionospheric plasma density irregularities generated by the turbulent flow of the EEJ current
- the electric fields and ionospheric plasma drifts in the dip equatorial zone
- the quiet counter equatorial electrojet CEJ
- temporal variabilities of the above phenomenon.

Typical EEJ Model Evaluation

Onwumechili (1966a, b, c; 1967) presented a two dimensional empirical model of the continuous current distribution responsible for EEJ as:

$$j = \frac{j_0 a^2 (a^2 + \alpha x) b^2 (b^2 + \beta z^2)}{(a^2 + x^2)^2 (b^2 + z^2)^2} \quad (1)$$

Where j ($\mu\text{A m}^{-2}$) is the eastward current density at the point (x, z) . The origin is at the centre of the current, x is northwards, and z is downwards. The model is extensible to three dimension by introducing the coordinate y or longitude θ or eastwards local time t . j_0 is the current density at the centre, a and b are constant latitudinal and vertical scale lengths respectively, α and β are dimensionless parameters controlling the current distribution latitudinally and vertically respectively.

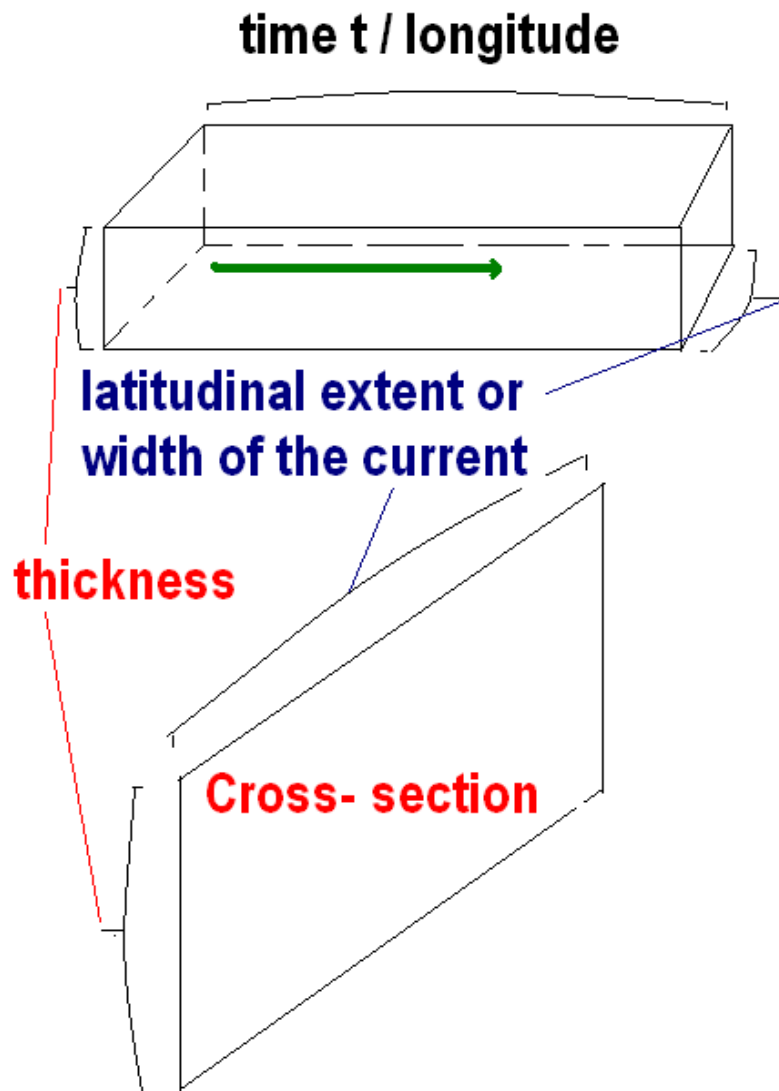

A Schematic diagram of EEJ current sheet



Derivable EEJ parameters

- peak intensity of the forward current at its centre J_o A/km;
- peak intensity of the return current, J_m A/km;
- ratio of the peak return to the peak forward current intensity
 J_m/J_o ;
- total forward current flowing between the current foci
 I_{fwd} kA;
- half of the latitudinal width or the focal distance from the current centre,
 w ;
- distance of the peak return current location from the current centre,
 x_m ;
- half thickness of the peak current density, p ;
- latitudinal extent of the current from its centre, $L1^\circ$;
- dip latitude of the electrojet centre x_o° .

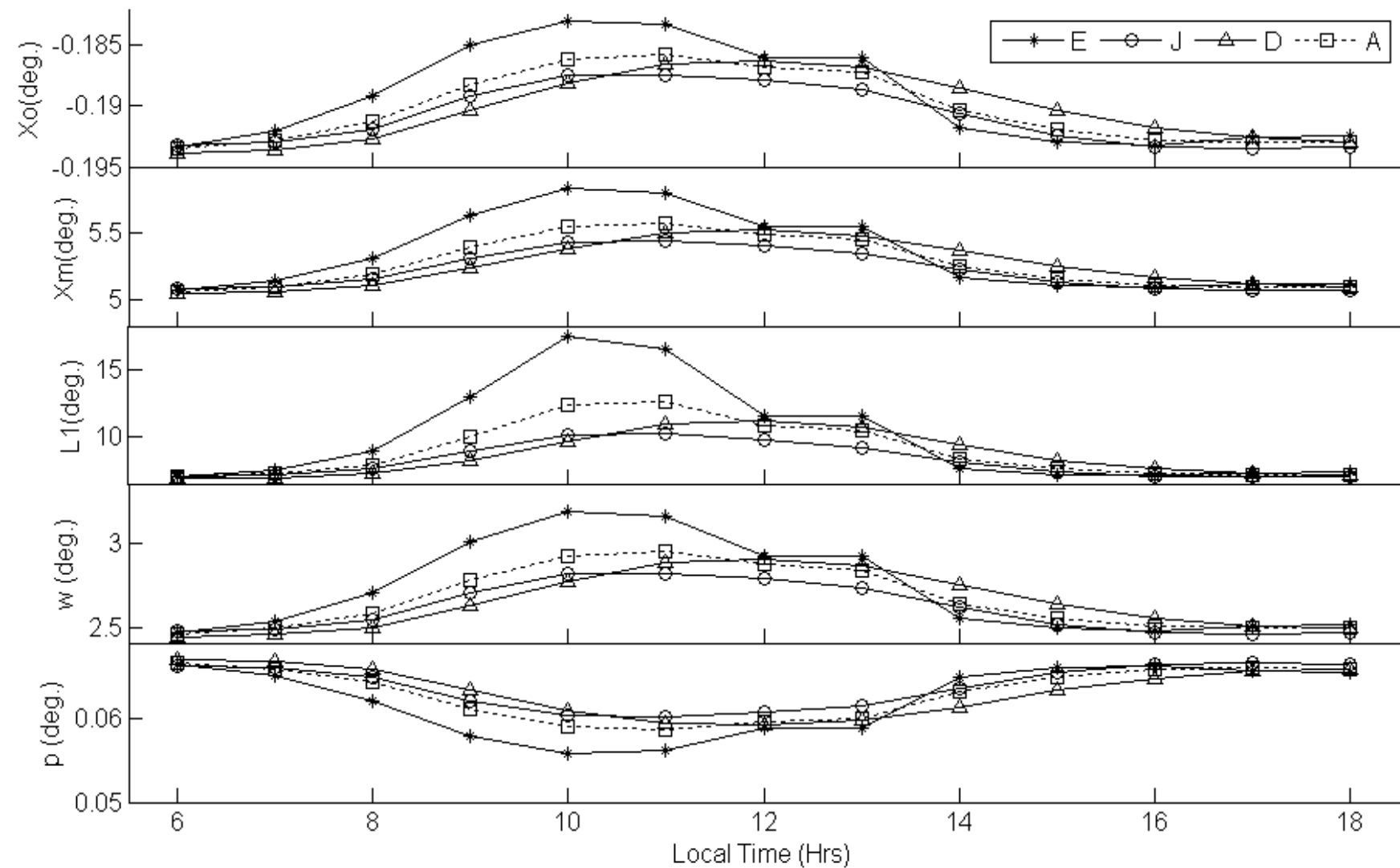

Diurnal variations of the landmark distances of EEJ parameters over India

Rabiu, et al. 2013

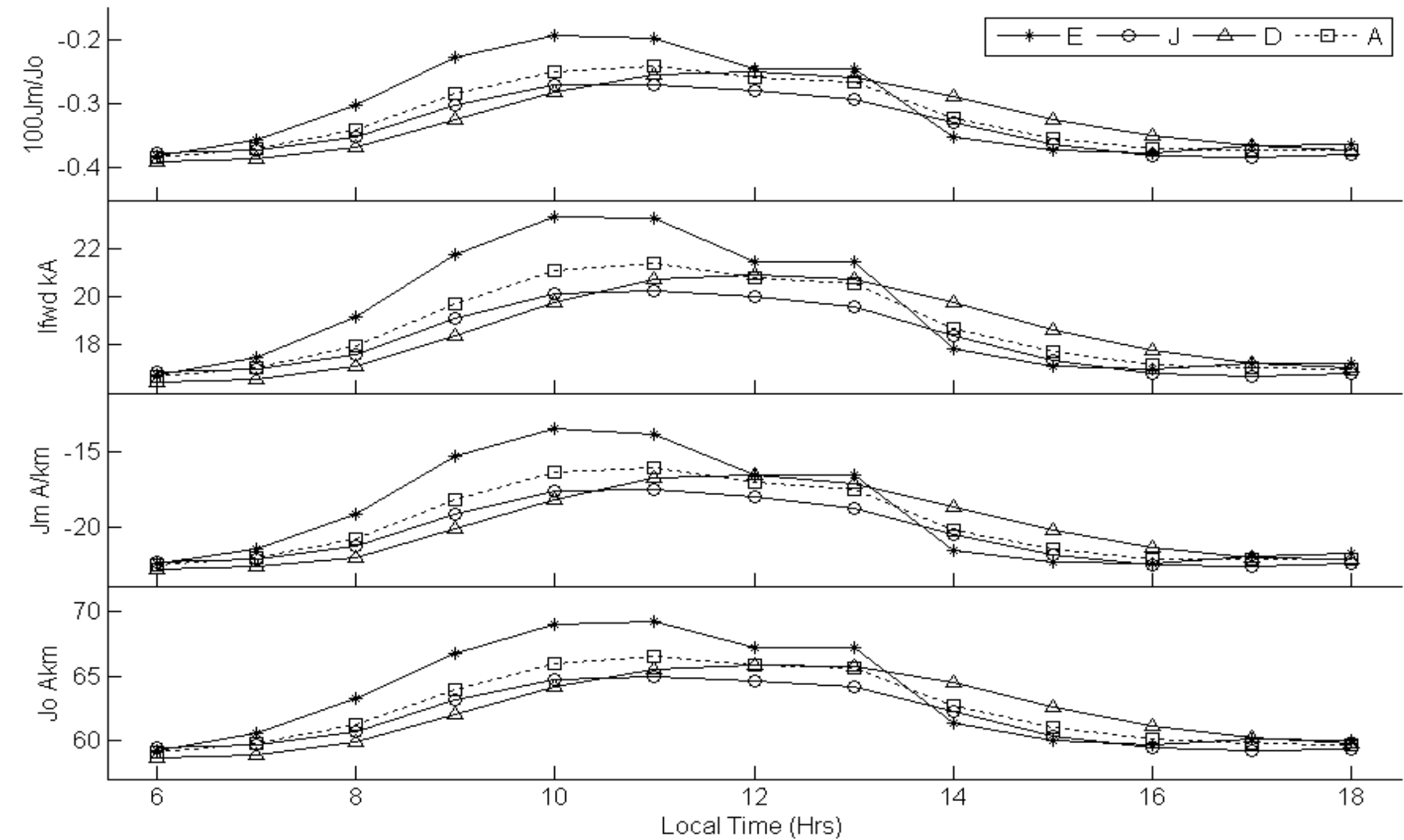

Diurnal variations of the landmark measures of the of EEJ current over India.

Rabiu, et al. 2013

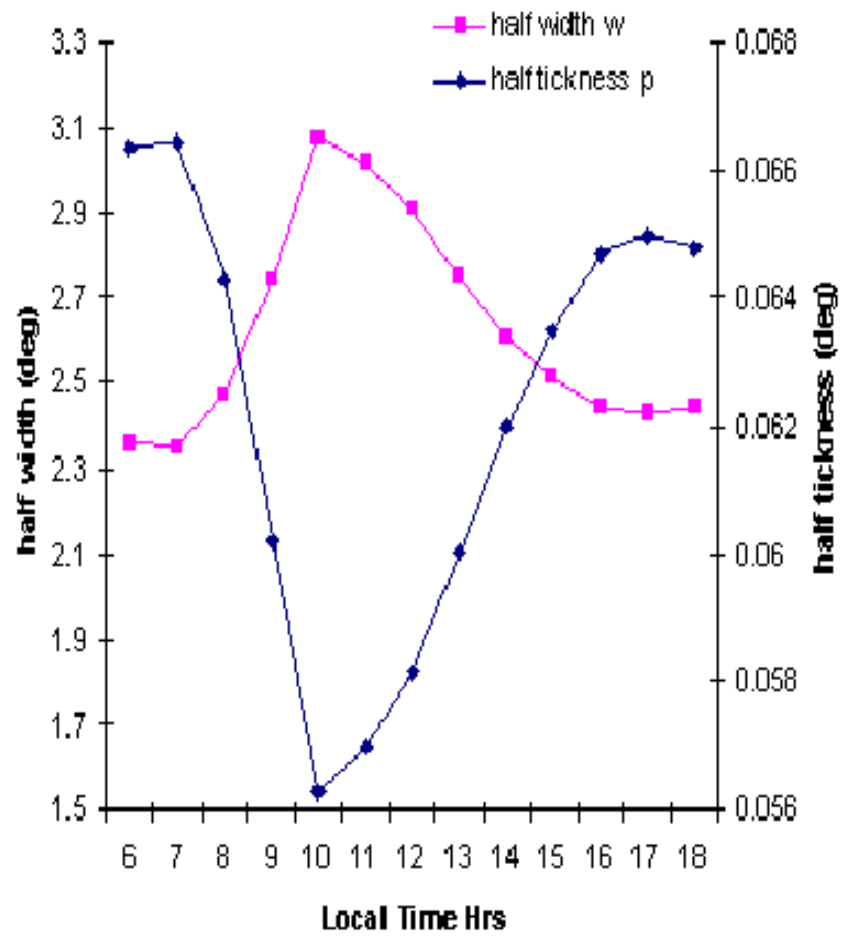
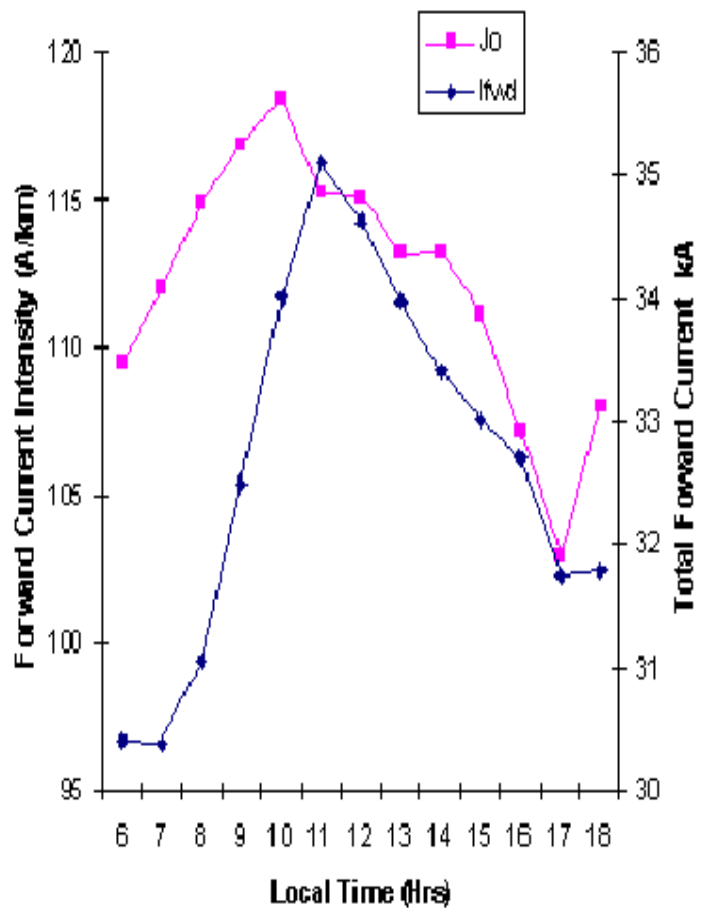

Forward Current Intensity & Total Forward Current

Half width and half thickness of EEJ

EEJ along 210 MM

(Rabiu et al, 2009)

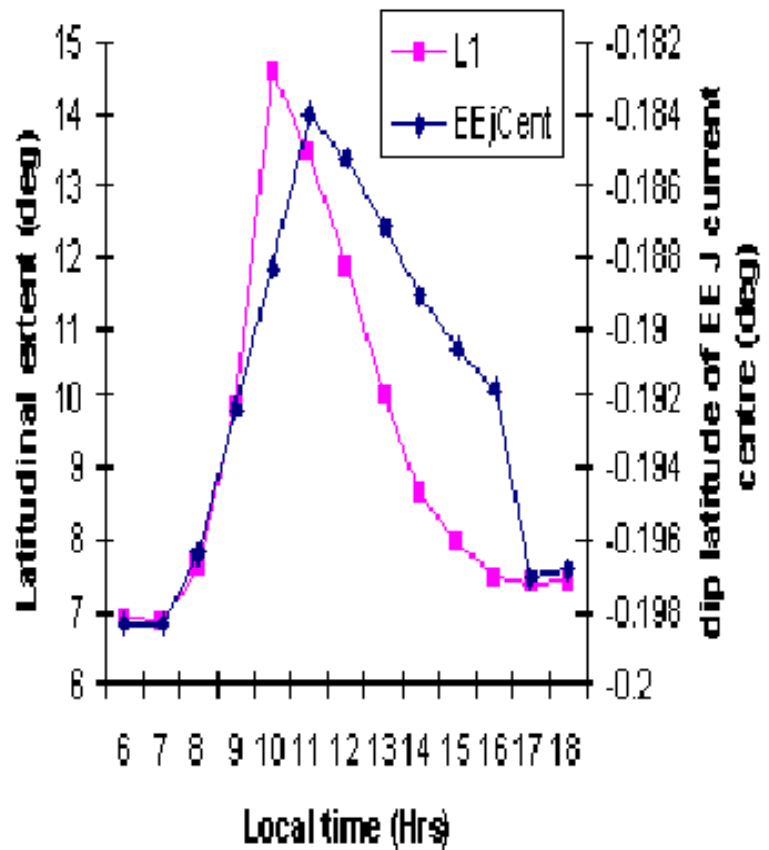

Latitudinal extent and dip latitude of EEJ centre

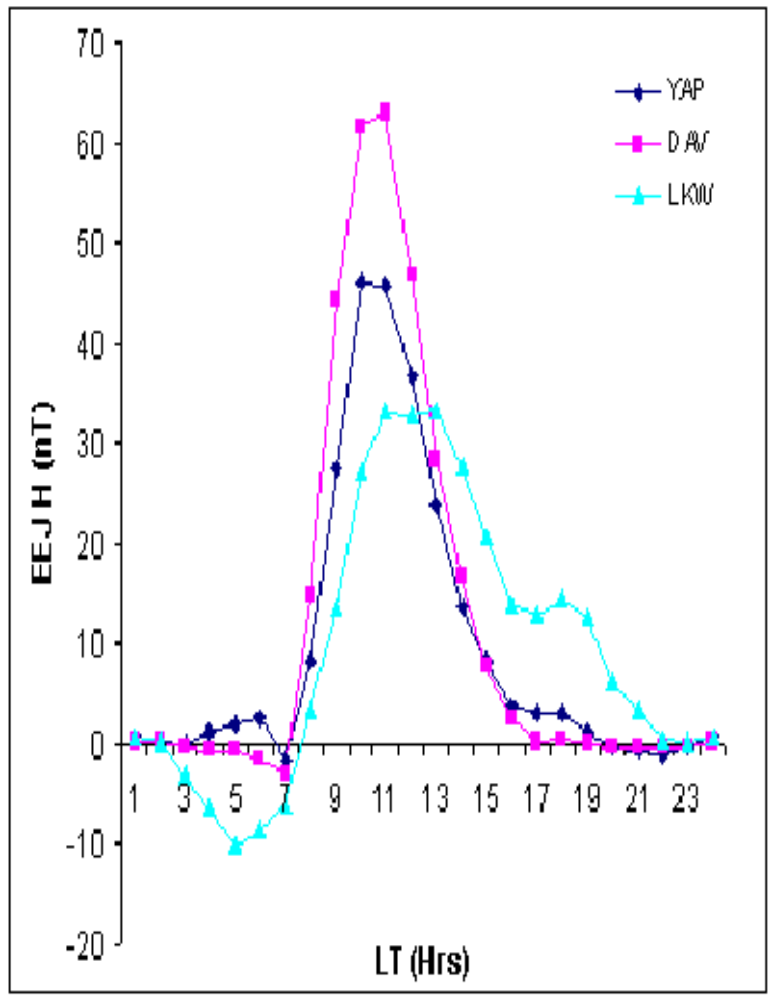

EEJ Strength at the stations

EEJ along 210 MM

(Rabiu et al, 2009)



LONGITUDINAL VARIABILITY OF EEJ

Comparison of EEJ at 210 MM with Indian & Brazil sectors

	Jo	Jm	Jm/Jo	Ifwd	Dip latitude of EEJ center
210 MM	112.13	-33.80	-0.299	32.67	-0.192
Indian Sector	62.97	-19.48	-0.312	19.01	-0.190
Brazil	148.00	-43.70	-0.290	67.00	-0.189

For 210° MM : Rabiou et al: (2009);
Brazil Sector: Rigoti et al, (1999);
Indian Sector: Rabiou et al (2013)

Coordinates of the Stations

OBS	GMLat°	GLong ° E	GLat°
ILR	-1.82	4.67	8.50°N
LAG		3.43	3.42°N
AAB	0.18	38.77	9.04°N
NAB		36.80	1.16°S

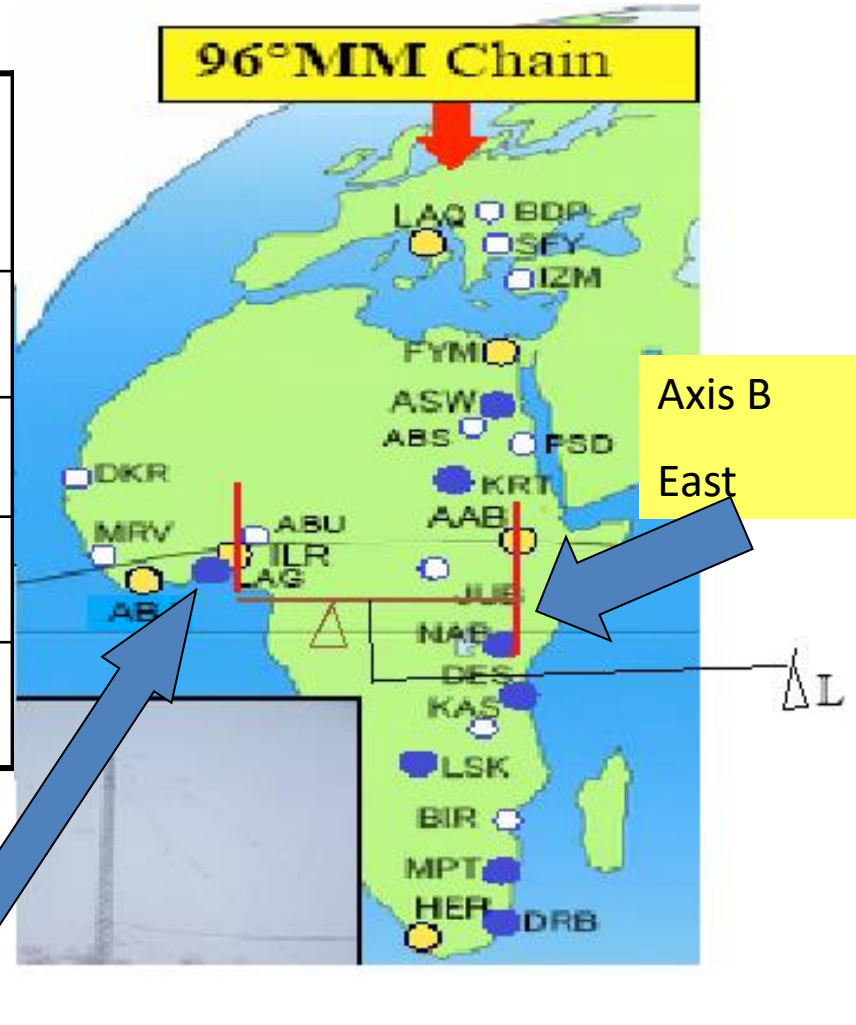

Separation of axes, $\Delta L = 33.735^\circ = 3744.585 \text{ km}$

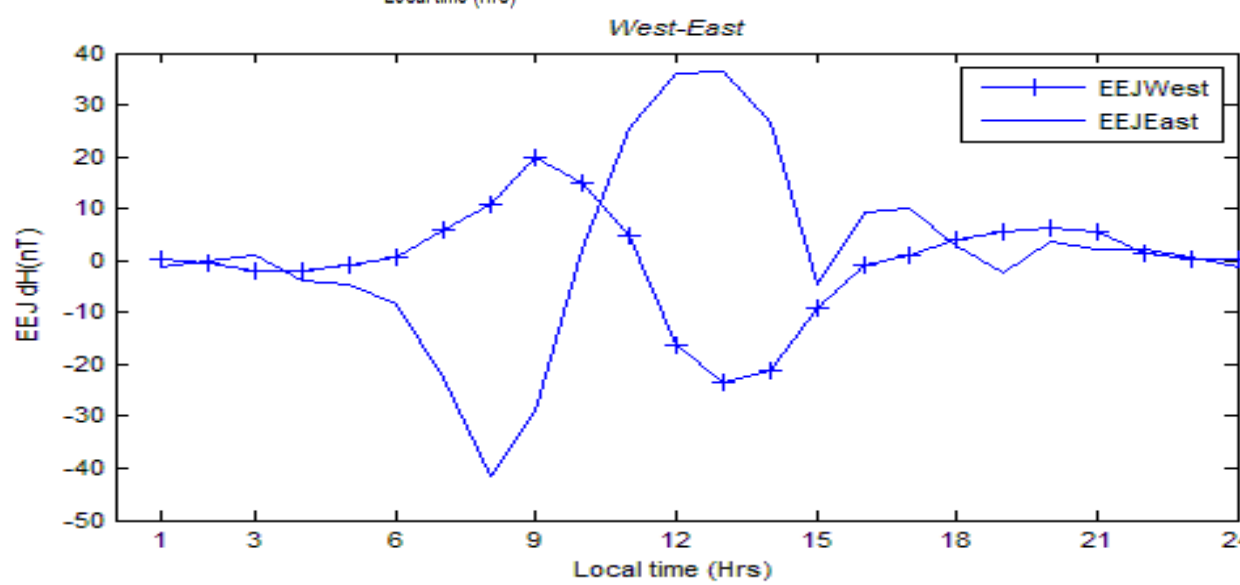
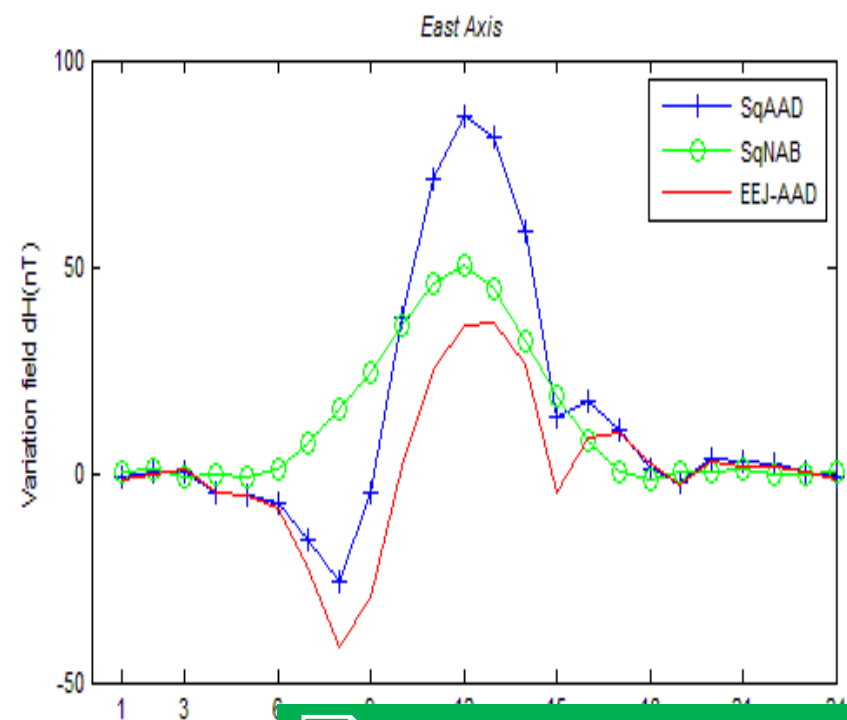
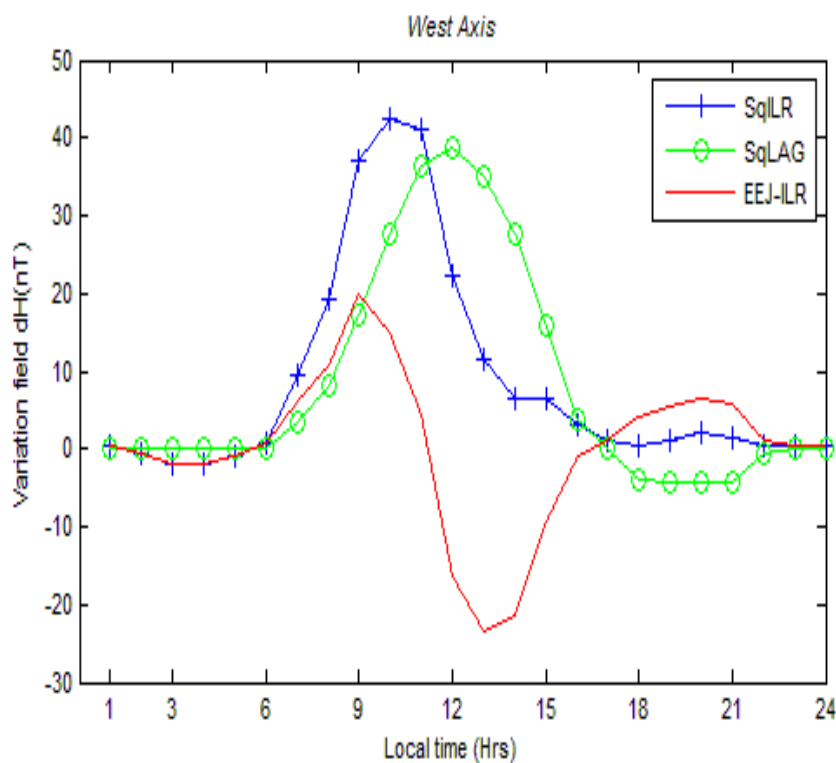

Western EEJ appears weaker than Eastern EEJ!

It is as if there is a process of re-injection of energy as Jet flows eastward

Rabiu et al., 2011

East-West Asymmetry in the African Equatorial Ionosphere

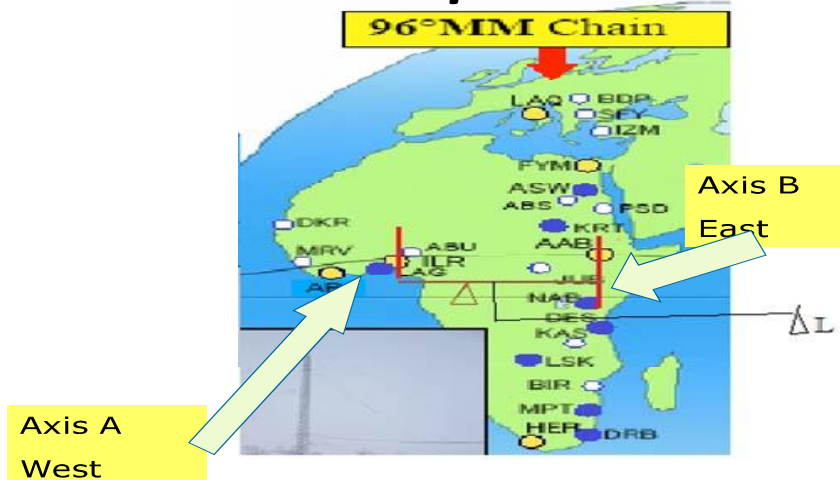

- Rabiou et al., (2011) for the first time clearly revealed that the western African EEJ appears weaker than eastern EEJ
- This discrepancy suggests that there is a process of re-injection of energy in the jet as it flows eastward
- This West-East Asymmetrical behavior in the EEJ strength in the African sector is further confirmed by Rabiou et al (2015) and Yizengaw et al., (2014) using data set from another set of array of magnetometers (AMBER).

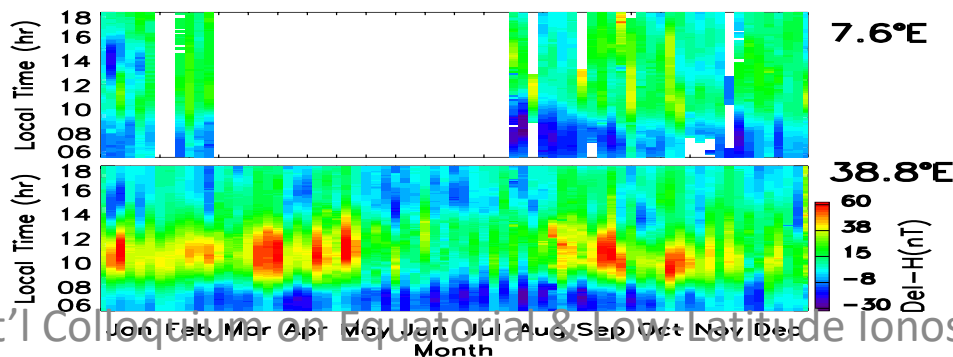
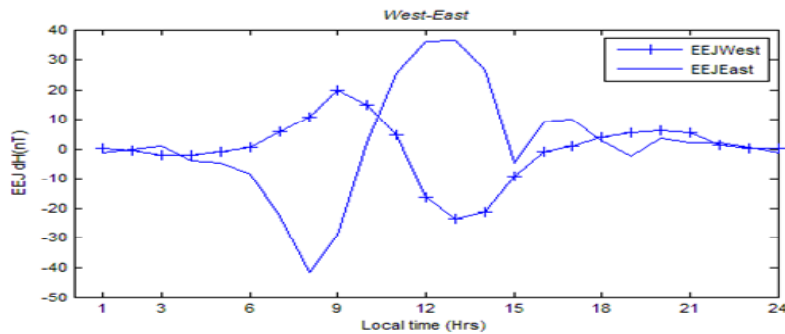

Longitudinal variation of EEJ

- ✓ the African stations registered the greatest % of occurrence of the CEJ than elsewhere
- ✓ The greatest % occurrence of MCEJ as found at Addis Ababa (eastern Africa)
- ✓ the greatest % occurrence of afternoon CEJ was found at Ilorin (western Africa).

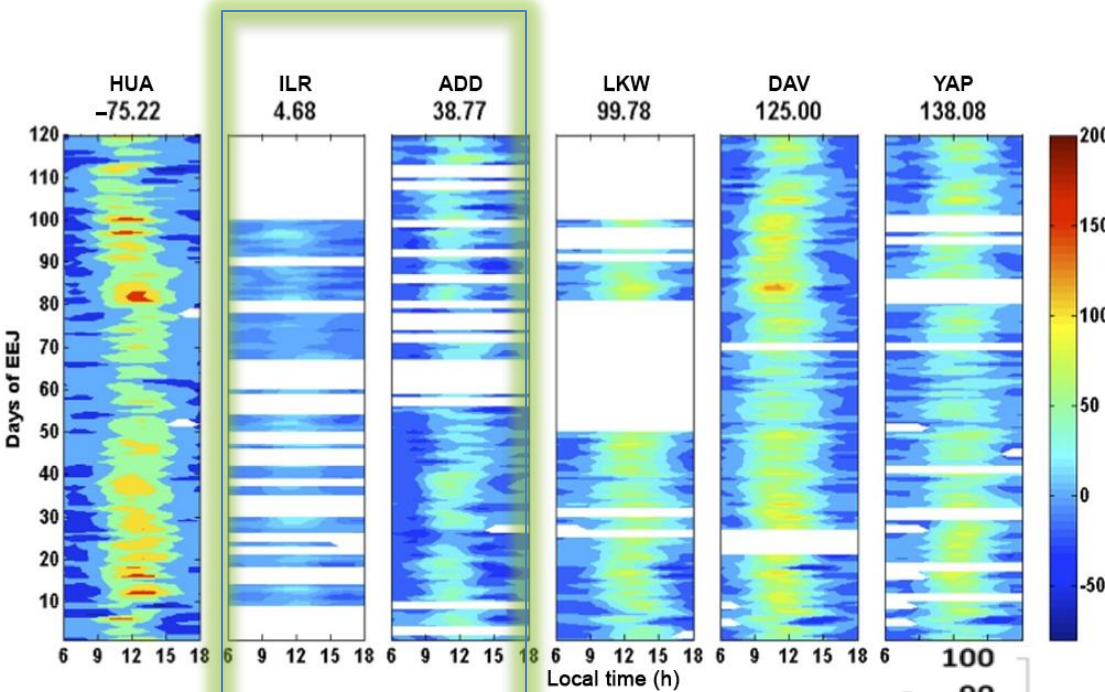

Variation of EEJ

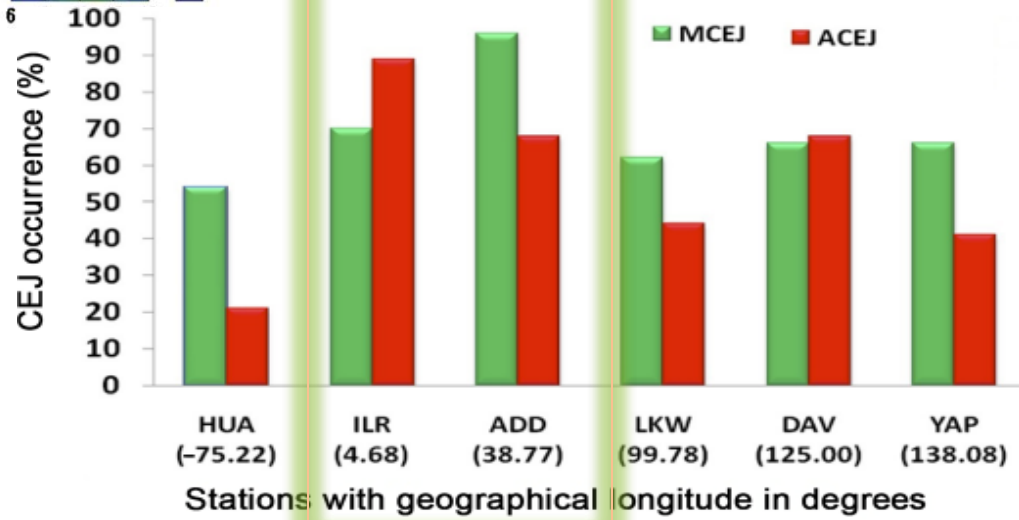

activities that support strong EEJ do inhibit occurrence of the CEJ.

Yearly % of occurrence of CEJ

Seasonal variation of Sq(H) along the African low latitudes

- Sq (H) is greater in all seasons in the neighbourhood of dip equator
- Obviously due to EEJ effect
- Max effect at Autumn (Sept) Equinox

Bolaji et al 2015 ..

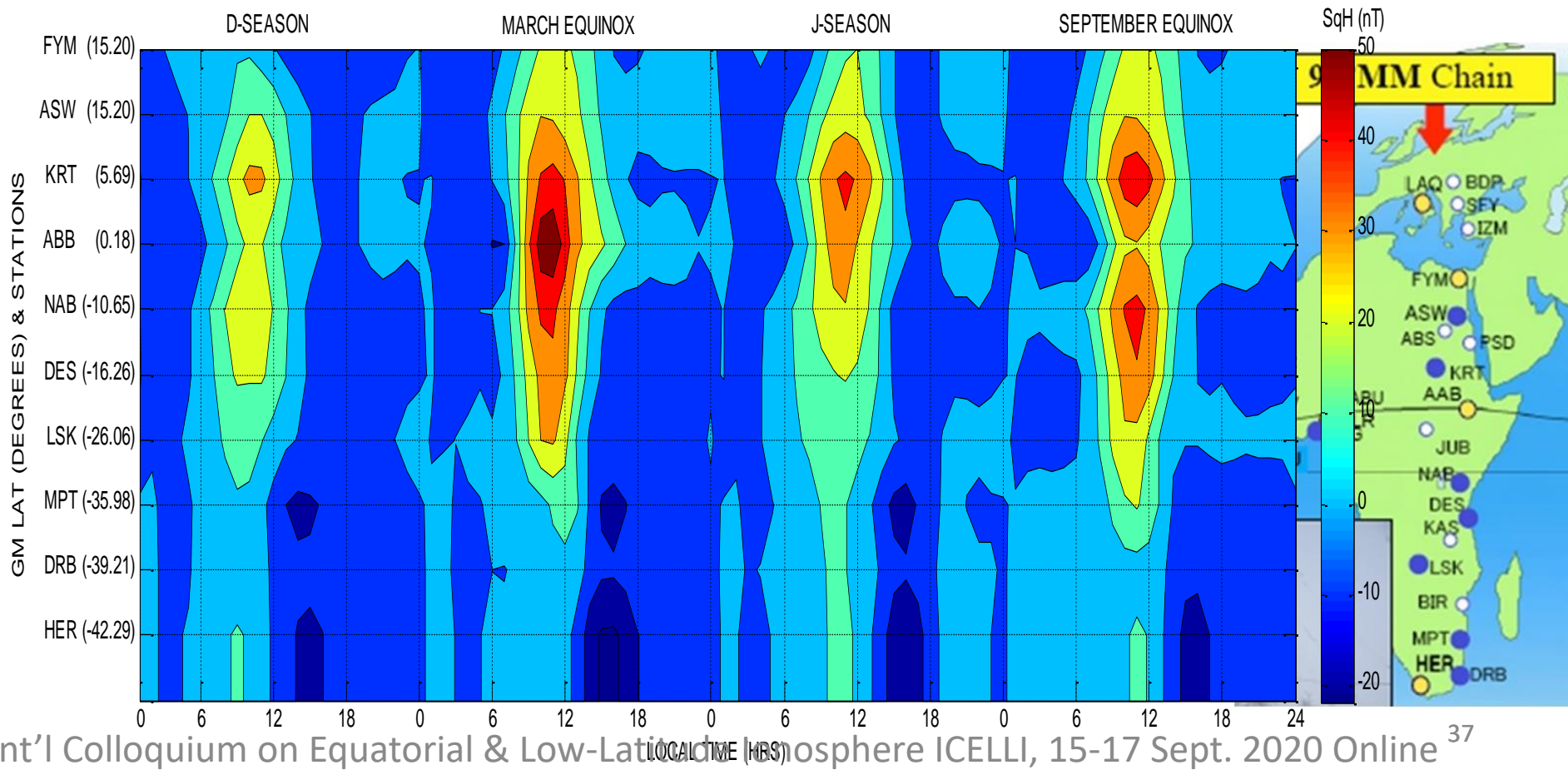



Nighttime plasma drift over Ouagadougou using ionosonde data

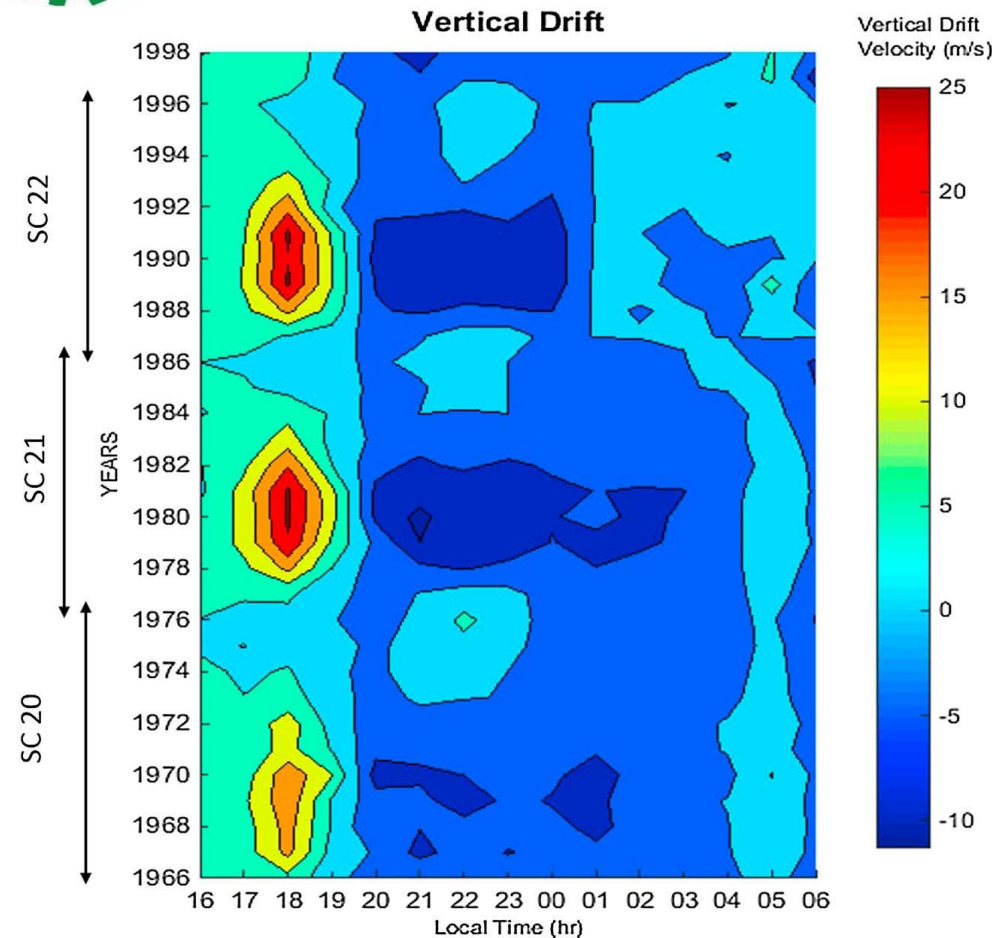

- ✓ A remarkable feature is the consistent local sunrise drift enhancement for two SCs 20 and 21, which is not a regular feature of the equatorial ionosphere
- ✓ The rate of inhibition of scintillation effect increases with decreasing phase of sunspot activity and maximizes during the solstices.
- ✓ Both the PRE and minimum reversal peak magnitudes are influenced by the phase of sunspot cycle

Adebesin et al, 2015



Plasma hubbles over Nigeria using Optical imager data

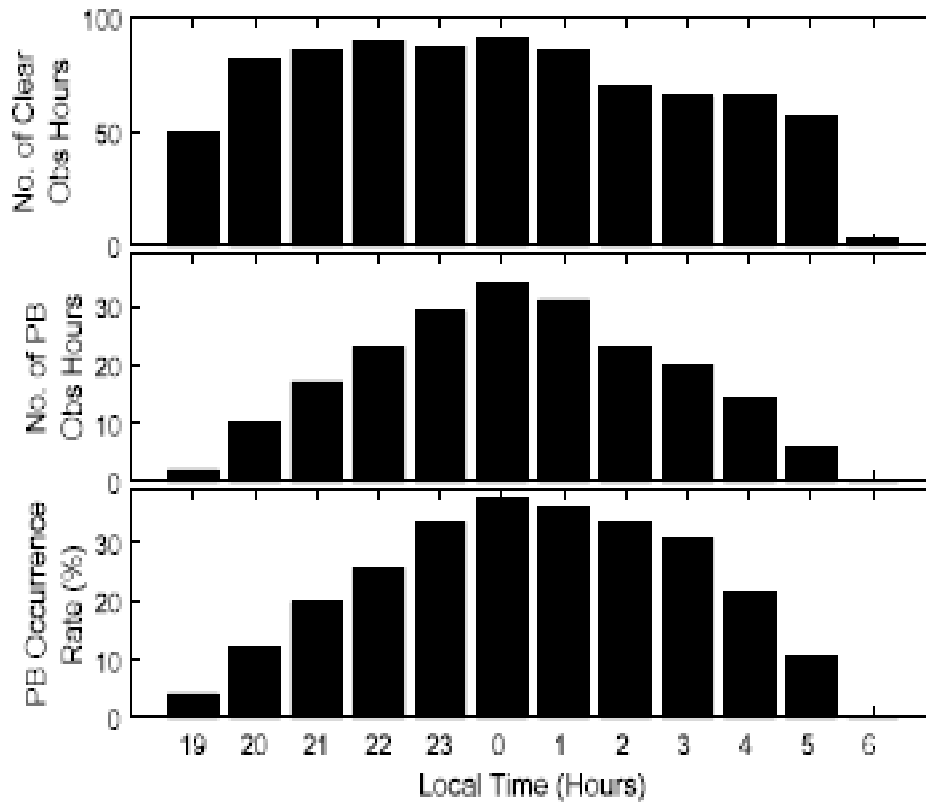

Figure 8. Percentage occurrence of plasma bubbles on the airglow images as a function of local time.

Percentage Occurrence of Plasma Bubbles as observed on the Airglow and GNSS data for the period from June 2015 to January 2017.

Okoh et al, 2017



Institute for Space-Earth Environmental Research

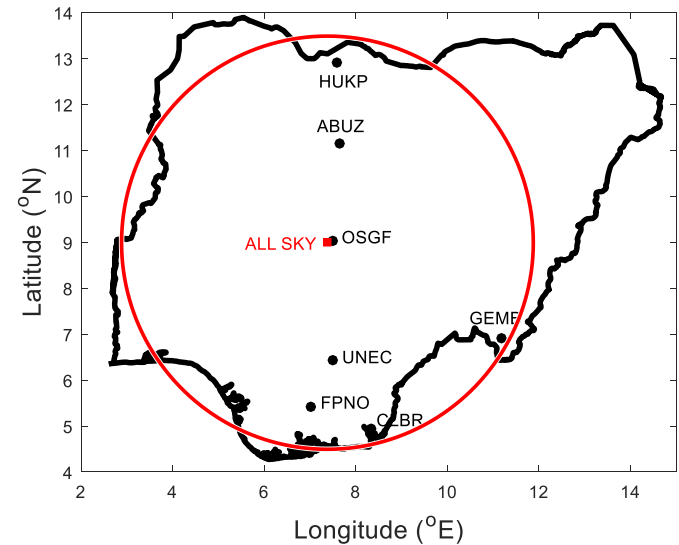

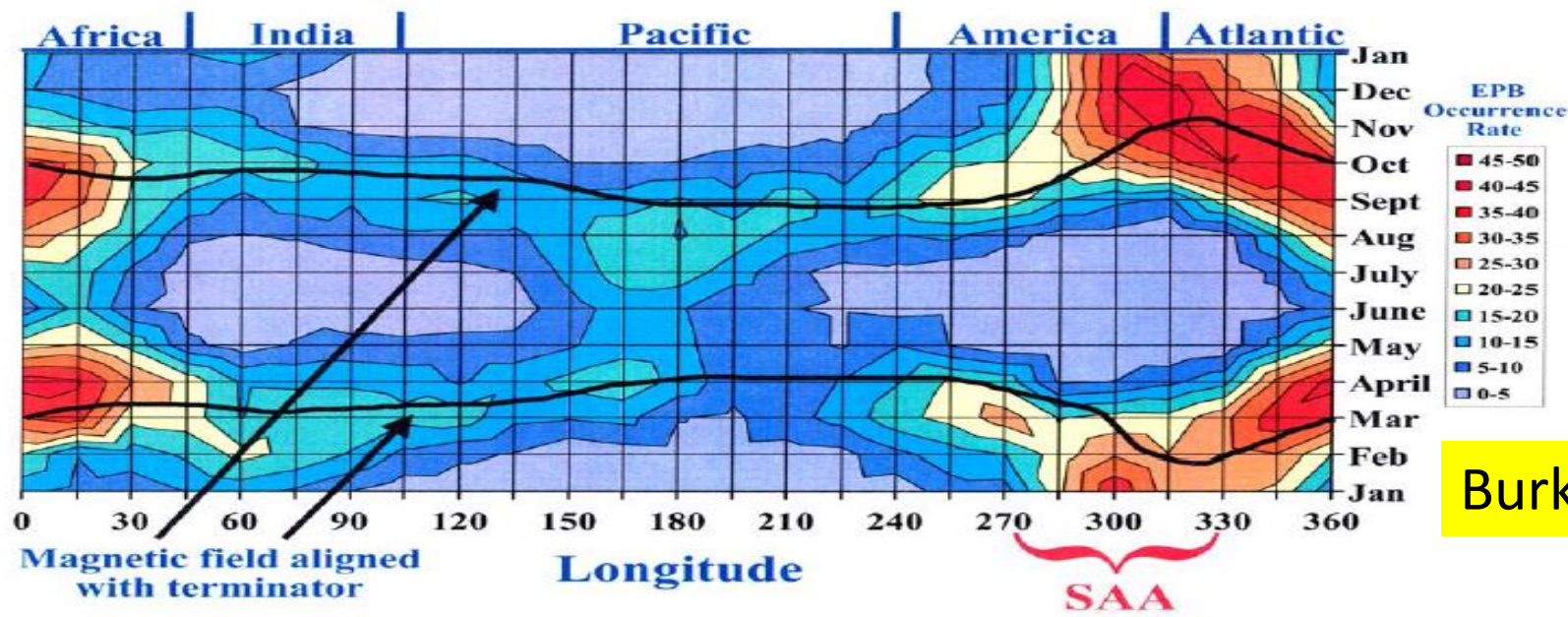

Burke et al., 2000

Figure 1. Contours of equatorial plasma bubble (EPB) occurrence rates measured by DMSP satellites between 1989 and 2002 plotted on a month versus longitude grid in nine 5% increments. The solid lines indicate the two times per year when $\alpha = 0^\circ$ at given longitudes.

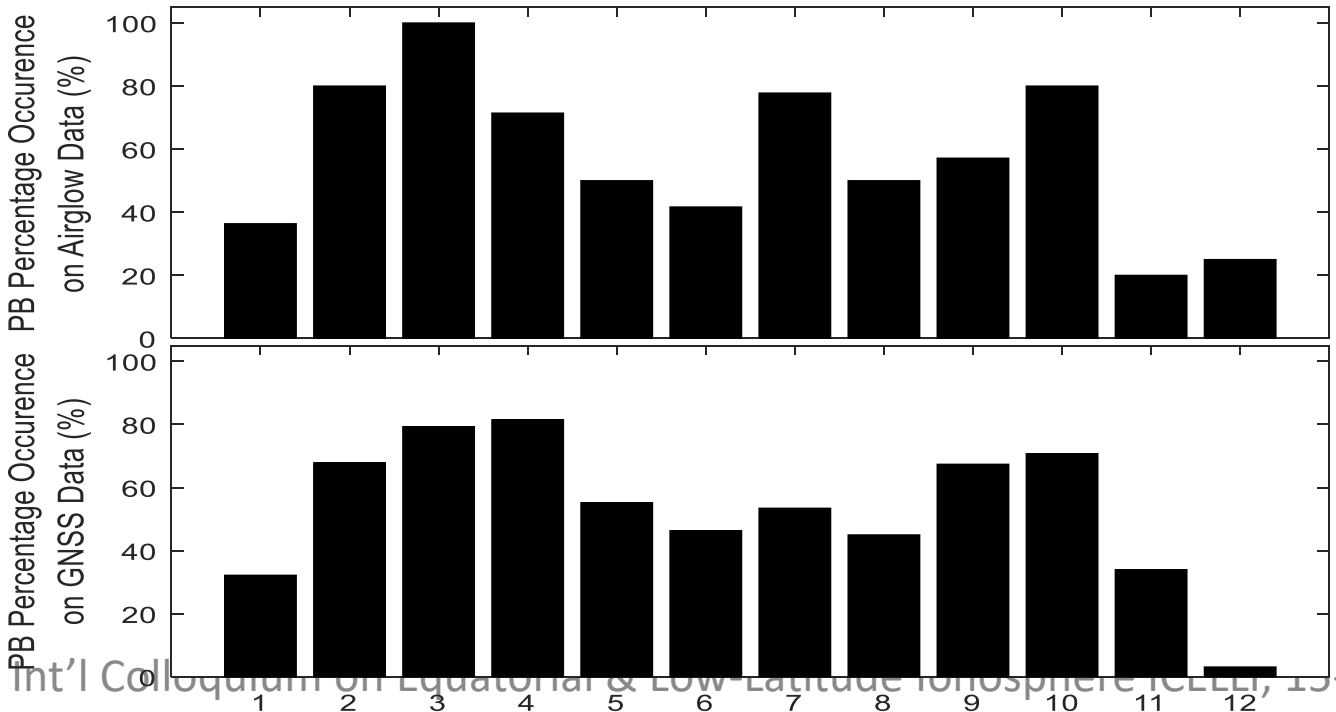

Percentage Occurrence of Plasma Bubbles as observed on the Airglow and GNSS data for the period from June 2015 to January 2017.

Okoh et al, 2017

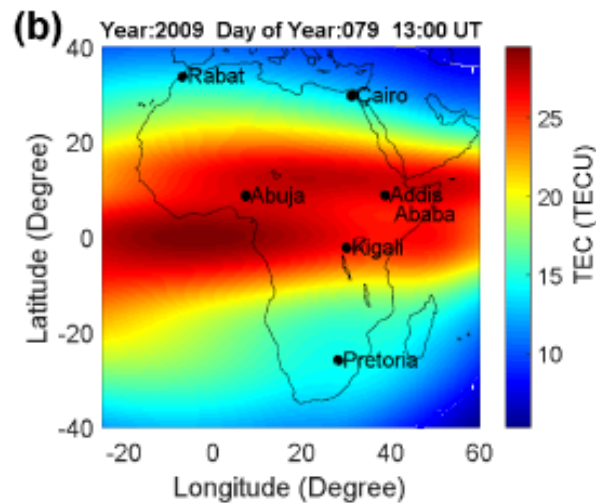
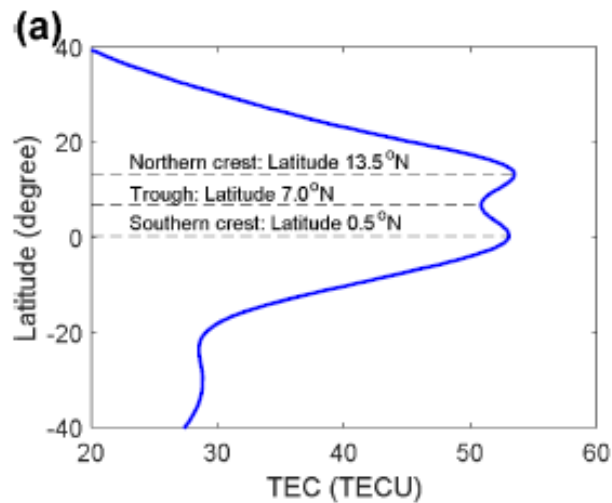

Okoh et al., JGR 2020

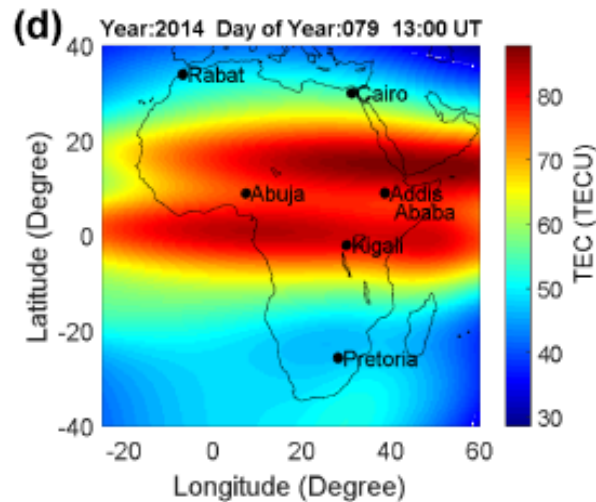
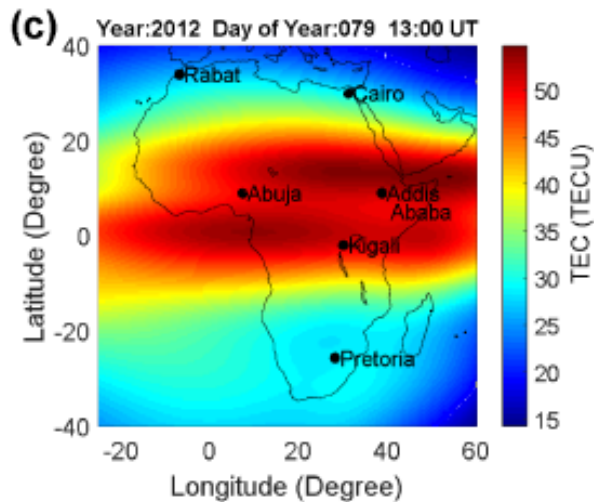

(a) Sample TEC profile for longitude 20°E illustrating the determination of anomaly crest and trough locations. The illustrated profile is for the March equinox day of year 2012. (b) to (d) are spatial simulations of TEC from the AfriTEC model for 13:00 UT of day number 79 of years 2009, 2012, and 2014, respectively. The F10.7 values are respectively 68, 101, and 150.

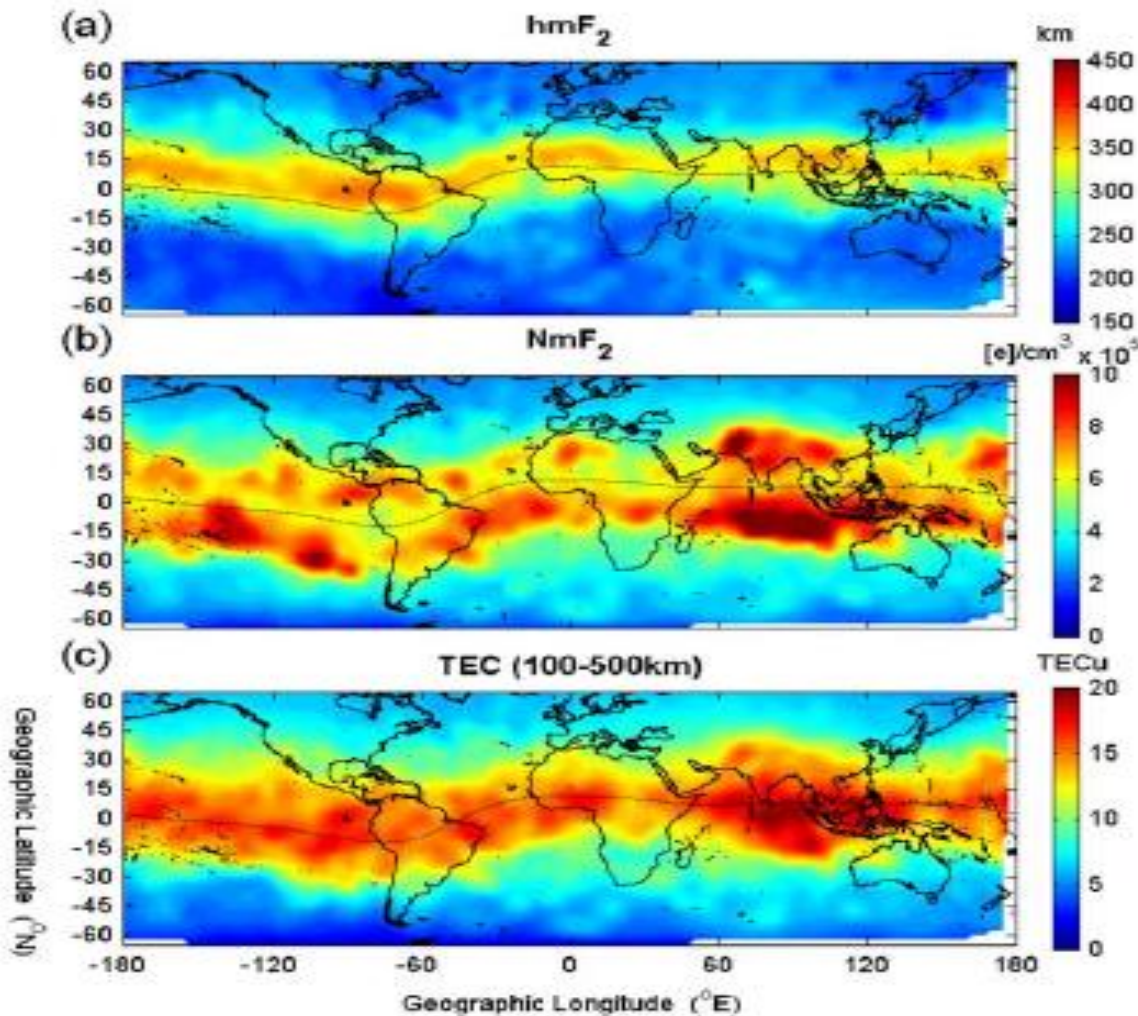

These longitudinal variations in EIA may be due to differences in:

- magnetic declination
- E x B drift, and
- neutral winds in different longitudes.

Lin et al., 2007

Ionospheric maps in (a) peak altitude (hmF₂), (b) peak density (NmF₂), and (c) total electron content (TEC) integrated between 100–500 km altitude range at global constant local time at 1200 LT.



**Radars Facility at
Central University
Taiwan**

October 2008



Nigerian Bowen Equatorial Aeronomy RADAR NigerBEAR

Equivalent of SuperDARN in low latitude



Centre for Atmospheric Research

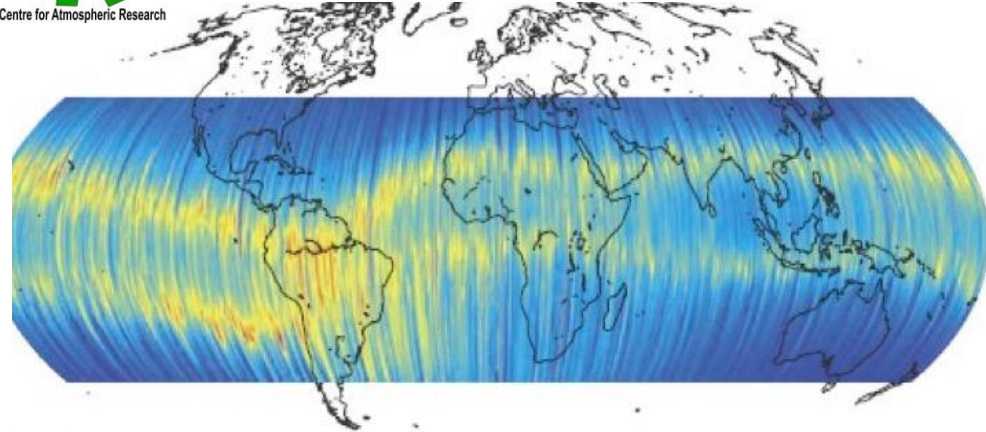

- **Bowen University, Iwo Nigeria**
- **1st of its kind in low latitudes**
- **enhancement of research capability**
- **new science results that could improve our understanding of the equatorial ionosphere and space weather**
- **multi-technique approach to study the ionosphere**

Global research infrastructure

